

# 1. Product Description

The Nexto XF is a powerful Programmable Logic Controller (PLC), belonging to the family of controllers and I/O modules of the Nexto Series. The Nexto XF provides high-speed processing power in a compact design with integrated I/O, easily expandable with external I/O modules. There are several options available, allowing you to choose the best solution regardless of the complexity of the application.

This product portfolio targets small, medium and distributed control systems, offering models with a range of options of I/O integrated points that includes digital and analog inputs and outputs concentrated in a single controller. For additional I/O needs, the system can be easily expanded through expansion modules coupled to the high-speed bus (refer to [Related Products](#) section). Additionally, the number of I/O points can be further increased through remote (distributed) I/O devices communicating via protocols such as CANopen, EtherNet/IP, PROFINET, EtherCAT, and MODBUS.

The Nexto XF is suitable for small to medium applications and remotely distributed I/O. It can be used in applications such as infrastructure, building and factory automation (food, textile, packaging, general machinery), water and wastewater treatment and numerous OEM solutions. Integrated solutions of firewall and VPN adds security to ensure data integrity and reduce risks associated to cybersecurity threats. Additionally, the controller is an ideal solution to complement large applications along with the Nexto Series portfolio, extending the range of applications using the same technology and engineering environment. This is a significant advantage for OEMs and system integrators with different range of applications needs and scales.



Key features include:

- Compact and modern design
- DIN rail mounting
- High-speed bus I/O expansion
- High-performance 64-bit Dual-Core ARM processor
- Two 10/100 Mbps Ethernet interfaces with protocols such as OPC UA, EtherNet/IP, PROFINET, EtherCAT, MODBUS, and MQTT (complete list in this document)
- Web service (Webvisu)
- Docker Engine
- Firewall and VPN
- CAN interface (CANopen and J1939)
- RS-485 interface (ModBus-RTU, Master/Slave)
- High I/O density (up to 44 integrated I/O points in the controller)
- Opto-isolated digital inputs
- Encoder inputs (quadrature)
- Opto-isolated transistor digital outputs
- PTO outputs
- Dedicated analog voltage and current inputs
- Analog voltage or current outputs
- Memory card (microSD)
- USB host port (V2.0)
- LEDs for I/O status indication and diagnostics
- Real-time clock (RTC)
- Retentive memory
- Compliance with international standard (IEC 61131-3)
- Fanless cooling (no moving parts)
- Battery-free
- Conformal coating

## 2. Ordering Information

### 2.1. Included Items

The product packaging includes the following items:

- CLP module with integrated I/O XF3xx
- 40-pin connector
- 20-pin connector
- 3-pin connector
- 2 x 4-pin connectors
- Nexto XF bus terminator
- CPU embedded I/O cable cover

### 2.2. Product Code

The following code should be used to purchase the product:

Code	Description
<b>XF300-B</b>	High-speed compact PLC with 16 digital inputs, 16 transistor digital outputs, 2 Ethernet ports, 1 RS-485 port, 1 CAN port, USB Host, and microSD card. Support for basic protocols only.
<b>XF300</b>	High-speed compact PLC with 16 digital inputs, 16 transistor digital outputs, 2 Ethernet ports, 1 RS-485 port, 1 CAN port, USB Host, and microSD card.
<b>XF315</b>	High-speed compact CLP with 16 digital inputs, 16 transistor digital outputs, 6 current analog inputs, 4 voltage analog inputs, 2 Ethernet ports, 1 RS-485 port, 1 CAN port, USB Host, and microSD card.
<b>XF325</b>	High-speed compact PLC with 16 digital inputs, 16 transistor digital outputs, 6 current analog inputs, 4 voltage analog inputs, 2 analog outputs (V/I), 2 Ethernet ports, 1 RS-485 port, 1 CAN port, USB Host, and microSD card.
<b>XF325-W</b>	High-speed compact PLC with 16 digital inputs, 16 transistor digital outputs, 6 current analog inputs, 4 voltage analog inputs, 2 analog outputs (V/I), 2 Ethernet ports, 1 RS-485 port, 1 CAN port, USB Host, microSD card and user web page support.

Table 1: Nexto XF Controller Models

### 3. Related Products

The following products must be purchased separately when necessary:

Code	Description
<b>MT9000</b>	Mastertool X
<b>NX9202</b>	RJ45-RJ45 2 m Cable
<b>NX9205</b>	RJ45-RJ45 5 m Cable
<b>NX9210</b>	RJ45-RJ45 10 m Cable
<b>AL-2600</b>	RS-485 network branch and terminator
<b>AL-2306</b>	RS-485 cable for MODBUS or CAN network
<b>NX9101</b>	32 GB microSD memory card with miniSD and SD adapters
<b>AL-1766</b>	CFDB9-Terminal Block Cable
<b>FBS-USB-232M9</b>	Universal USB-Serial converter cable / 2m
<b>XP900</b>	TP-Link nano Wireless 150 Mbps USB Adapter TL-WN725N (only available in Brazil)
<b>AMJG0808</b>	Simple cable RJ45-RJ45 2 m
<b>TLE3-21100</b>	Gateway IoT Industrial
<b>XF101</b>	24Vdc 16 DI module
<b>XF201</b>	24Vdc 16 DO transistor module
<b>XF600</b>	6 AI voltage/current module 12bit
<b>XF610</b>	8 AI thermocouple module
<b>XF620</b>	8 AI RTD module
<b>XF700</b>	4 AO voltage/current module 12bit
<b>XF900</b>	Nexto XF bus terminator
<b>XF901</b>	CPU embedded I/O cable cover
<b>XF902</b>	I/O module cable cover

Table 2: Related Products

**Notas:**

**NX92xx:** Cable for programming the CPUs of the Nexto Series and Ethernet point-to-point with another device with ethernet interface communication.

**AL-2600:** This module is used for branch and termination of RS-485 networks. For each network node, an AL-2600 is required. The AL-2600 that are at the ends of network must be configured with termination, except when there is a device with active external termination, the rest must be configured without termination.

**AL-2306:** Two shielded twisted pairs cable without connectors, used for networks based on RS-485 or CAN.

**AL-1766:** Cable with a female DB9 connector and terminals for communication between HMI P2 and Nexto XF controller.

**FBS-USB-232M9:** Cable for use as a USB-Serial converter on the USB interface of XF controllers.

**AMJG0808:** Cable for programming the CPUs.

## 4. Product Features

### 4.1. General Features

	XF300-B	XF300	XF315	XF325	XF325-W
Digital inputs	16 (9 fast)				
Digital outputs	16 (8 fast)				
Max. number of high-speed counters	3				
Max. number of external interruptions	9				
Max. number of PTO outputs	3				
Max. number of VFO/PWM outputs	8				
Analog voltage inputs	-		4	4	4
Analog current inputs	-		6	6	6
Analog V/I outputs	-		-	2	2
Ethernet TCP / IP interface	2				
Ethernet interface redundancy support	Yes				
RS-485 serial interface	1				
CAN interface	1				
USB Host port	1				
Max number of I/O expansion modules supported	10				
Max number of I/O expansion modules supported with additional power supply expansion	32				
User web pages (Webvisu)	No				Yes, 2048 tags
Docker engine	No			Yes	
I/O Channels	128	512			
Communication Tags	512	2048			4096
Mapped points	20480				
Communication Protocols	See table <a href="#">Protocols</a>				
FTP	Yes				
Firewall	Yes				
VPN	Yes				
Programming languages	Structured Text (ST) Ladder Diagram (LD) Sequential Function Chart (SFC) Function Block Diagram (FBD) Continuous Function Chart (CFC)				
Online changes	Yes				
Maximum number of tasks	16				
Watchdog	Yes				
Status and diagnosis	LEDs, web page and internal CPU memory				
Real-time clock (RTC)	Yes 1 ms resolution, max. variation of 3 seconds per day, retention time of 7 days.				
Isolation					
Protective earth $\oplus$ to all	1000 Vdc / 1 minute (700 Vac / 1 minute)				
Logic/USB to all	1000 Vdc / 1 minute (700 Vac / 1 minute)				

<b>Power supply to all</b>	1000 Vdc / 1 minute (700 Vac / 1 minute)
<b>NET1 to all</b>	1000 Vdc / 1 minute (700 Vac / 1 minute)
<b>NET2 to all</b>	1000 Vdc / 1 minute (700 Vac / 1 minute)
<b>CAN to all</b>	1000 Vdc / 1 minute (700 Vac / 1 minute)
<b>RS-485 to all</b>	1000 Vdc / 1 minute (700 Vac / 1 minute)
<b>Analog I/O to all</b>	1000 Vdc / 1 minute (700 Vac / 1 minute)
<b>Digital inputs to all</b>	1000 Vdc / 1 minute (700 Vac / 1 minute)
<b>Digital inputs group I0x to I1x</b>	1000 Vdc / 1 minute (700 Vac / 1 minute)
<b>Digital outputs to all</b>	1000 Vdc / 1 minute (700 Vac / 1 minute)
<b>Maximum power dissipation</b>	10 W
<b>Maximum wire size</b>	0.5 mm <sup>2</sup> (20 AWG) with ferrule 1.5 mm <sup>2</sup> (16 AWG) without ferrule
<b>Minimum wire temperature rating</b>	75 °C
<b>Wire material</b>	Copper only
<b>IP level</b>	IP 20
<b>Conformal coating</b>	Yes
<b>Operating temperature</b>	-20 to 60 °C
<b>Storage temperature</b>	-40 to 70 °C
<b>Operating and storage relative humidity</b>	10% to 95%, non-condensing
<b>Vibration resistance (IEC 60068-2-6, sinus)</b>	3.5 mm from 5 to 8.4 Hz 1 G from 8.4 to 500 Hz 10 sweeps each axis, 1 octave per minute
<b>Shock resistance (IEC 60068-2-27, half-sine)</b>	15 G for 11 ms, 6 shocks in each of 3 axis
<b>Product dimensions (W x H x D)</b>	100.0 x 115.5 x 123.3 mm (without cable cover 111.0 mm)
<b>Package dimensions (W x H x D)</b>	107.4 x 132.9 x 130.5 mm
<b>Weight</b>	500.0 g
<b>Weight with package</b>	550.0 g

Table 3: General Features

**Notes: I/O Channels:** This refers to the number of individual input and output channels used by the application. In each device's view, the I/O channels can be accessed through the I/O Mapping screen.

**Communication Tags:** Communication Tags are variables explicitly designated for data exchange between the controller and external systems using OPC UA.

**Mapped points:** It is the maximum number of mapped points that the CPU supports. Each mapping can contain one or more mapped points, depending on the data size. This varies depending on whether simple variables or ARRAY-type variables are used. Each simple variable, as well as each index of an ARRAY, is counted as a mapped point, even if it occupies more than one address in the driver. For example, a simple DWORD-type variable mapped in the MODBUS protocol will be counted as a single point, even though it occupies two consecutive addresses/registers in the driver

**Isolation:** The term *Logic* refers to the processing circuit that is electrically isolated from the interfaces, with the exception of the USB interface.

**Conformal coating:** Conformal coating protects the electronic components inside the product from moisture, dust and other harsh elements to electronic circuits.

## 4.2. Standards and Certifications



Standards and Certifications	
<b>IEC</b>	<p>61131-2: Industrial-process measurement and control - Programmable controllers - Part 2: Equipment requirements and tests</p> <p>61131-3: Programmable controllers - Part 3: Programming languages</p>
	Certification process in progress
<b>CE</b>	Certification process in progress
<b>UK CA</b>	Certification process in progress
	<p>Ordinary and Hazardous Locations (C1D2): cULus LISTED</p> <p>Certification process in progress</p>

Table 4: Standards and Certifications

### 4.3. Memory

	XF300-B	XF300	XF315	XF325	XF325-W
Addressable input variables memory (%I)	64 KB				
Addressable output variables memory (%Q)	64 KB				
Direct representation variable memory (%M)	32 KB				
Symbolic variable memory	10 MB				
Program memory	32 MB				
Total memory Program memory + Source code memory (backup) + Webvisu files memory	256 MB				
Retain/persistent memory	128 KB				
User files memory Memory of the CPU + Docker Memory	2.5GB				

Table 5: Memory

### 4.4. Performance

Instruction	Language	Variable Type	Time ( $\mu$ s)
1000 Contacts	LD	BOOL	2.1
1000 Divisions	LD, ST	INT	9.2
		REAL	17.0
1000 Multiplications	LD, ST	INT	6.4
		REAL	8.2
1000 Sums	LD, ST	INT	4.4
		REAL	8.2

Table 6: Instruction Times

## 4.5. Protocols

	Interface	XF300-B	XF300	XF315	XF325	XF325-W
EtherCAT master PROFINET controller EtherNet/IP scanner	NET 1 / NET 2	✗	1 instance (total)*			
EtherNet/IP adapter	NET 1 / NET 2	1 instance (total)*	2 instance (total)*			
PROFINET device	-	✗	✗			
CANopen master CAN low level SAE J1939 CODESYS MODBUS RTU master CODESYS MODBUS TCP client CODESYS MODBUS RTU over TCP client	CAN COM 1 NET 1 / NET 2	2 instance (total)*	4 instance (total)*			
CODESYS MODBUS RTU slave	-	✗	✗			
CODESYS MODBUS TCP server	-	✗	✗			
CODESYS MODBUS RTU over TCP server	-	✗	✗			
CANopen slave	-	✗	✗			
Open protocol	COM 1 / USB	✓	✓			
Symbolic MODBUS RTU master Symbolic MODBUS RTU slave	COM 1	1 instance (total)**	1 instance (total)**			
Symbolic MODBUS TCP client Symbolic MODBUS TCP server Symbolic MODBUS RTU over TCP client Symbolic MODBUS RTU over TCP server	NET 1 / NET 2	8 instance (total)**	8 instance (total)**			
IEC 60870-5-104 client	-	✗	✗			
IEC 60870-5-104 server	-	✗	✗			
DNP3 client	-	✗	✗			
DNP3 server	-	✗	✗			
OPC DA server	NET 1 / NET 2 / USB	✓	✓			
OPC UA server	NET 1 / NET 2 / USB	✓	✓			
SNMP agent	NET 1 / NET 2 / USB	✓	✓			
MQTT client	NET 1 / NET 2 / USB	✓	✓			
SNTP client (clock synchronism)	NET 1 / NET 2 / USB	✓	✓			
OpenVPN client	NET 1 / NET 2 / USB	✓	✓			
OpenVPN server	NET 1 / NET 2 / USB	✓	✓			
FTP server	NET 1 / NET 2 / USB	✓	✓			
RSTP	NET 1 / NET 2	✓	✓			
MRP	NET 1 / NET 2	✓	✓			

Table 7: Protocols

**Notes:**

\*: The *I/O Channels* limit shall be consulted as specified in the [General Features](#) table.

\*\* : The *Mapped points* limit shall be consulted as specified in the [General Features](#) table.

**USB:** The use of a Serial Converter, WiFi Adapter or 3G/4G Modem is necessary.

## 4.6. RS-485 Interface

<b>RS-485</b>	
<b>Conector</b>	4-pin terminal block (D+, D-, GND and shield)
<b>Physical interface</b>	RS-485 bus
<b>RS-485 max. transceivers</b>	32
<b>Termination</b>	Yes (through mechanical switch)
<b>Baud rate</b>	2400, 4800, 9600, 19200, 38400, 57600, 115200 bps
<b>Isolation</b>	
<b>Logic to serial port</b>	1000 Vac / 1 minute
<b>Serial port to protection earth</b> ⊕	1000 Vac / 1 minute

Table 8: RS-485 Serial Interface Features

## 4.7. CAN Interface

<b>CAN</b>	
<b>Conector</b>	4-pin terminal block (H, L, GND and shield)
<b>Physical interface</b>	CAN bus
<b>Supported standards</b>	CAN 2.0A 2.0B (11-bit and 29-bit identifiers)
<b>Max. number of nodes</b>	64
<b>Termination</b>	Yes (through mechanical switch)
<b>Baud rate</b>	10, 20, 50, 100, 125, 250, 500, 800, 1000 kbit/s
<b>Isolation</b>	
<b>Logic to CAN</b>	1000 Vac / 1 minute
<b>CAN to protection earth</b> ⊕	1000 Vac / 1 minute

Table 9: CAN Interface Features

## 4.8. Memory Card Interface

The memory card can be used for different data to be stored such as user logs, project documentation and source files.

Memory Card	
<b>Maximum Capacity</b>	32 GB
<b>Minimum Capacity</b>	2 GB
<b>Type</b>	MicroSD
<b>File System</b>	FAT32
<b>Safe card removal</b>	Yes, via physical button

Table 10: Memory Card Interface Features

**Notes:**

**Maximum Capacity:** The memory card capacity must be less than or equal to this limit for correct operation on Nexto CPU, otherwise the Nexto CPU may not detect the memory card or even present problems during data transfer.

**Minimum Capacity:** The memory card capacity must be greater than or equal to this limit for correct operation on Nexto CPU, otherwise the Nexto CPU may not detect the memory card or even present problems during data transfer.

**File System:** It is recommended to format the memory card using the Nexto CPU, otherwise it may result in performance loss in the memory card interface.

## 4.9. USB Interface

USB	
<b>Conector</b>	USB A female
<b>Physical interface</b>	USB V2.0
<b>Baud rate</b>	1.5 Mbps (Low-Speed), 12 Mbps (Full-Speed) and 480 Mbps (Hi-Speed)
<b>Maximum current</b>	500 mA
<b>Supported devices</b>	Mass storage USB RS-232 serial converter USB 3G/4G modem USB WiFi adapter
<b>Isolation</b>	
<b>Logic to USB</b>	Not isolated
<b>USB to protection earth</b> 	1000 Vac / 1 minute

Table 11: USB Interface Features

**Attention:**

The CPU supports the use of only one USB device at a time. Devices such as USB hubs are not supported.

#### 4.9.1. List of Supported Devices

##### 4.9.1.1. RS-232 Converter

Controller	Manufacturer
FT232	FTDI
PL2303	Prolific

Table 12: Supported USB to RS-232 converters

##### 4.9.1.2. 3G/4G Modem

Model	Manufacturer	Type	Remarks
E303	Huawei	Bridge	-
E3272	Huawei	Bridge	-
E3276	Huawei	Bridge	-
E8372	Huawei	Router	The redirection of the configuration web page (button <i>Open Modem Page</i> ) is not compatible with this model. Router configuration must be done externally on a PC.

Table 13: Supported USB modems

##### 4.9.1.3. WiFi Adapter

Chipset	Manufacturer	Example of comercial products
RTL8188EU	Realtek	TP-LINK model TL-WN725N LM Technologies model LM007
RT28xx	Ralink/Mediatek	D-Link model DWA-125
AR9271	Atheros/Qualcomm	TP-LINK model TL-WN721N

Table 14: Supported chipsets for USB WiFi adapters

## 4.10. Ethernet Interface

	<b>Ethernet</b>
<b>Interfaces</b>	NET1 and NET2
<b>Connector</b>	Shielded female RJ45
<b>Auto crossover</b>	Yes
<b>Maximum cable length</b>	100 m
<b>Cable type</b>	UTP or ScTP, category 5
<b>Baud rate</b>	10/100 Mbps
<b>Physical layer</b>	10/100 BASE-TX
<b>Data link layer</b>	LLC
<b>Network layer</b>	IP
<b>Transport layer</b>	TCP (Transmission Control Protocol) UDP (User Datagram Protocol)
<b>Operation mode</b>	Single / NIC Teaming / Switch
<b>Diagnostics</b>	LED (Link/Activity)
<b>Isolation</b>	
<b>Ethernet interface to logic</b>	1000 Vac / 1 minute
<b>Ethernet interface to ethernet interface</b>	1000 Vac / 1 minute
<b>Ethernet interface to protection earth</b> Ⓧ	1000 Vac / 1 minute

Table 15: Ethernet Interface Features

## 4.11. Power Supply

	<b>Power supply</b>
<b>Nominal input voltage</b>	24 Vdc
<b>Input voltage</b>	18 to 30 Vdc
<b>Maximum input current</b>	1.4 A at 18 Vdc
<b>Maximum in-rush current</b>	15 A for 1 ms
<b>Maximum interruption time</b>	10 ms at 18 Vdc
<b>Number of I/O modules supported by integrated power supply</b>	10
<b>Input protections</b>	Polarity reversal Overvoltage Short-circuit (fuse) Overload and short-circuit on the I/O module bus
<b>Isolation</b>	
<b>Input to logic</b>	1000 Vac / 1 minute
<b>Input to protective earth</b> Ⓧ	1000 Vac / 1 minute

Table 16: Power Supply Features

## 4.12. Digital Inputs

	Digital inputs
Number of inputs	7
Type of inputs	Opto-isolated, sink/source
Connector identification	I00 to I06
Input voltage	24 Vdc 15 to 30 Vdc for logic level 1 0 to 5 Vdc for logic level 0
Input impedance	4.95 kΩ
Max. input current	6.2 mA at 30 Vdc
Input status indication	Yes
Response time	0.4 ms
Input filter	Disabled or configurable by software from 2 ms to 255 ms
Isolation	
Input to logic	1000 Vac / 1 minute
Input to protective earth 	1000 Vac / 1 minute

Table 17: Digital Inputs Features

**Nota:**

**Input Filter:** The filter sampling is performed in the MainTask (or update function), so it is recommended to use values that are multiples of the task interval.

## 4.13. Fast Digital Inputs

	Fast digital inputs
Number of fast inputs	9
Type of fast inputs	Opto-isolated sink/source
Maximum number of fast counters	3 (Increment/Decrement, A-pulse, B-direction, and Z-zero)
Maximum number of encoders	3 (Quadrature A, B, and Z)
Max. number of external interrupts	9 (Rise, Fall or Both)
Connector identification	I07 a I15
Input voltage	24 Vdc 15 to 30 Vdc for logic level 1 0 to 5 Vdc for logic level 0
Input impedance	3.9 kΩ
Max. input current	7.3 mA at 30 Vdc
Configuration mode	<b>Modes for 1 input:</b> Standard digital input External interrupt <b>Modes for 3 inputs:</b> Quadrature/Counter 0 (I07, I08, and I09) Quadrature/Counter 1 (I10, I11, and I12) Quadrature/Counter 2 (I13, I14, and I15)

	Fast digital inputs
<b>Direction control for counting</b>	Only through hardware
<b>Edge detection for counting input</b>	Rising edge, active at logic level 1 – default (support alternative settings)
<b>Data format</b>	32-bit signed integers
<b>Operation limit</b>	From -2,147,483,648 to 2,147,483,647
<b>Max. input frequency</b>	250 kHz
<b>Min. pulse width @24Vdc</b>	2 $\mu$ s
<b>Isolation</b>	
<b>Input to logic</b>	1000 Vac / 1 minute
<b>Input to protective earth</b> 	1000 Vac / 1 minute

Table 18: Characteristics of Fast Digital Inputs

#### 4.14. Digital Outputs

	Digital outputs
<b>Number of outputs</b>	8
<b>Type of outputs</b>	Transistor switch, opto-isolated, source
<b>Connector identification</b>	Q00 to Q07
<b>Max. current</b>	1.5 A per output (single) 6 A total
<b>Leakage current</b>	35 $\mu$ A
<b>Output resistance</b>	100 m $\Omega$
<b>External power supply</b>	19.2 to 30 Vdc
<b>Switching time</b>	3 $\mu$ s - off-to-on transition 50 $\mu$ s - on-to-off transition (400 $\Omega$ load at 24Vdc)
<b>Max. switching frequency</b>	250 Hz
<b>Configurable parameters</b>	Yes
<b>Output status indication</b>	Yes (LED)
<b>Output protections</b>	Yes (against voltage surges)
<b>Isolation</b>	
<b>Output to logic</b>	1000 Vac / 1 minute
<b>Output to protective earth</b> 	1000 Vac / 1 minute

Table 19: Characteristics of Digital Outputs

**Notes:**

**Switching time:** The time required to turn off an output depends the applied load.

## 4.15. Fast Digital Outputs

		<b>Fast digital outputs</b>	
<b>Number of outputs</b>	8		
<b>Output type</b>	Transistor switch, opto-isolated, source		
<b>Connector identification</b>	Q08 to Q15		
<b>Max. number of PTO outputs</b>	3		
<b>Max. number of VFO/PWM outputs</b>	8 (if not using PTO) 7 (when using 1 PTO) 6 (when using 2 PTOs) 5 (when using 3 PTOs)		
<b>Maximum current</b>	3 to 500 Hz: 1,5A per output (6.0 A total) 500 Hz to 250 KHz: 0.5 A per output		
<b>Pulse generation minimum frequency</b>	3 Hz from 60 mA		
<b>Pulse generation maximum frequency</b>	250 kHz from 60 mA		
<b>Minimum pulse width at 24 Vdc</b>	Minimum load	Positive pulse	
	400 $\Omega$	240 ns	
<b>Switching Time</b>	0.2 $\mu$ s - off-to-on transition 0.8 $\mu$ s - on-to-off transition (400 $\Omega$ load at 24Vdc)		
<b>Output status indication</b>	Yes (LED)		
<b>Protections</b>	Voltage surge (TVS)		
<b>Operating voltage</b>	19.2 to 30 Vdc		
<b>Output impedance</b>	200 m $\Omega$		
<b>Output modes</b>	Standard output VFO/PWM PTO (only Q08, Q09 e Q14)		
<b>Software managed functions</b>	PTO	VFO/PWM	
	Writing the number of pulses to be generated;  Writing the number of acceleration and deceleration pulses; Start/end outputs operation; Fast outputs diagnostics; Fast outputs monitoring state.	Writing the frequency value to be generated (3 Hz to 250 kHz, +/-1%);  Writing of outputs duty cycle (1% to 100%);  Start/end of outputs operations; Fast outputs diagnostics.	
<b>Isolation</b>	<b>Output to logic</b>	1000 Vac / 1 minute	
	<b>Output to protective earth</b> 	1000 Vac / 1 minute	

Table 20: Characteristics of Fast Digital Outputs

## 4.16. Analog Inputs

<b>Analog inputs</b>	
<b>Number of inputs</b>	10 (with 6 current and 4 voltage)
<b>Type of input</b>	Dedicated as voltage or current, single-ended, configured individually
<b>Data format</b>	16 bits in two's complement, left-justified
<b>Converter resolution</b>	12 bits monotonicity guaranteed, no missing codes
<b>Conversion time</b>	400 $\mu$ s (all channels enabled)
<b>Channel status indication</b>	Yes (LED)
<b>Protections</b>	Yes, protection against surge voltage and polarity inversion
<b>Isolation</b>	
<b>Channel to logic</b>	1000 Vac / 1 minute
<b>Channel to protective earth</b> 	1000 Vac / 1 minute

Table 21: Characteristics of Analog Inputs

<b>Voltage input</b>			
<b>Input range</b>	Range	Engineering Scale	Resolution
		0 to 10 Vdc	0 to 30,000
<b>Precision</b>	$\pm 0.3$ % of full scale @ 25 °C $\pm 0.010$ % of full scale / °C		
<b>Over scale</b>	3 % of full scale		
<b>Maximum input voltage</b>	14 Vdc		
<b>Input impedance</b>	21 k $\Omega$		
<b>Configurable parameters</b>	Filters		
<b>Low pass filter time constant</b>	100 ms, 1 s, 10 s or disabled		

Table 22: Characteristics of Voltage Analog Inputs

<b>Current input</b>			
<b>Input ranges</b>	Range	Engineering Scale	Resolution
	0 to 20 mA	0 to 30,000	5.03 $\mu$ A
	4 to 20 mA	0 to 30,000	5.03 $\mu$ A
<b>Precision</b>	$\pm 0.3$ % of full scale at 25 °C $\pm 0.015$ % of full scale / °C		
<b>Over scale</b>	3 % of full scale		
<b>Maximum input current</b>	30 mA		
<b>Input impedance</b>	119 $\Omega$		
<b>Configurable parameters</b>	Filters, open loop value		
<b>Low pass filter time constant</b>	100 ms, 1 s, 10 s or disabled		

Table 23: Current Input Mode Features

## 4.17. Analog Outputs

<b>Analog outputs</b>	
<b>Number of outputs</b>	2
<b>Output type</b>	Voltage or current output, individually configured
<b>Data format</b>	16 bits in two's complement, justified to the left
<b>Converter resolution</b>	12 bits monotonicity guaranteed, no missing codes
<b>Update time</b>	400 $\mu$ s (all outputs enabled)
<b>Channel status indication</b>	Yes (LED)
<b>Protections</b>	Yes, protection against surge voltage and polarity inversion
<b>Isolation</b>	
<b>Channel to logic</b>	1000 Vac / 1 minute
<b>Channel to protective earth</b> 	1000 Vac / 1 minute

Table 24: Analog Outputs Features

<b>Voltage output mode</b>			
<b>Output ranges</b>	Range	Engineering Scale	Resolution
		0 to 10 V	0 to 30,000
<b>Precision</b>	$\pm 0.3$ % of full scale at 25 °C $\pm 0.010$ % of full scale / °C		
<b>Stabilization time</b>	4 ms		
<b>Over scale</b>	3% of full scale		
<b>Load impedance</b>	> 1 k $\Omega$		
<b>Configurable parameters</b>	Signal type per output (voltage or current)		

Table 25: Voltage Output Mode Features

<b>Current output mode</b>			
<b>Output ranges</b>	Range	Engineering Scale	Resolution
	0 to 20 mA	0 to 30,000	5.03 $\mu$ A
	4 to 20 mA	0 to 30,000	5.03 $\mu$ A
<b>Precision</b>	$\pm 0.3$ % of full scale at 25 °C $\pm 0.015$ % of full scale / °C		
<b>Stabilization time</b>	4 ms		
<b>Over scale</b>	3% of full scale		
<b>Load impedance</b>	< 600 $\Omega$		
<b>Configurable parameters</b>	Signal type per output (voltage ou current)		

Table 26: Current Output Mode Features

**Notes:**

**Output ranges:** When configured as 4 to 20 mA, the output can be set to values below 4 mA by assigning negative values to the output variable (-7,500 for 0 mA).

## 5. Installation

### 5.1. Product Identification

This product has some parts that must be observed before installation and use. The following figure identifies each of these parts.

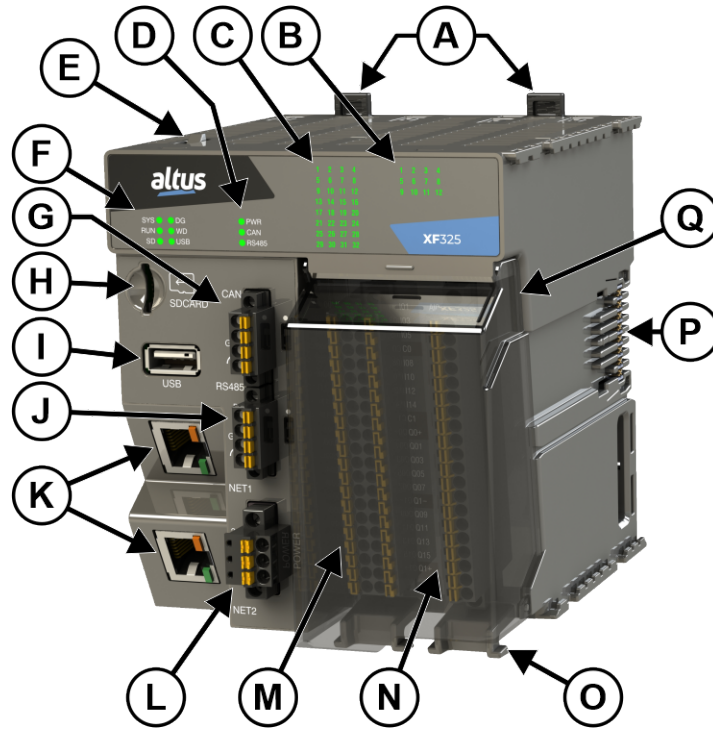

Figure 1: XF325

- Ⓐ DIN rail mounting latch.
- Ⓑ Status LEDs for embedded analog I/O.
- Ⓒ Status LEDs for embedded digital I/O.
- Ⓓ Status LEDs for PSU, CAN interfaces, and RS-485.
- Ⓔ Button.
- Ⓕ CPU status LEDs.
- Ⓖ 4-terminal connector for CAN interface and termination switch.
- Ⓗ SD card slot.
- Ⓘ USB device port.
- Ⓙ 4-terminal connector for RS-485 interface and termination switch.
- Ⓚ RJ45 ethernet connectors.
- Ⓛ 3-terminal connector for power input.
- Ⓜ 40-terminal connector for embedded digital I/O.
- Ⓝ 20-terminal connector for embedded analog I/O (not available for the XF300 and XF300-B).
- Ⓞ Support for holding the I/O cable.
- Ⓟ Slice connection for expansion modules.
- Ⓠ CPU embedded I/O cable cover.

## 5.2. Electrical Installation

**Danger**

When performing any installation in an electrical panel, ensure that the power supply is **TURNED OFF**.

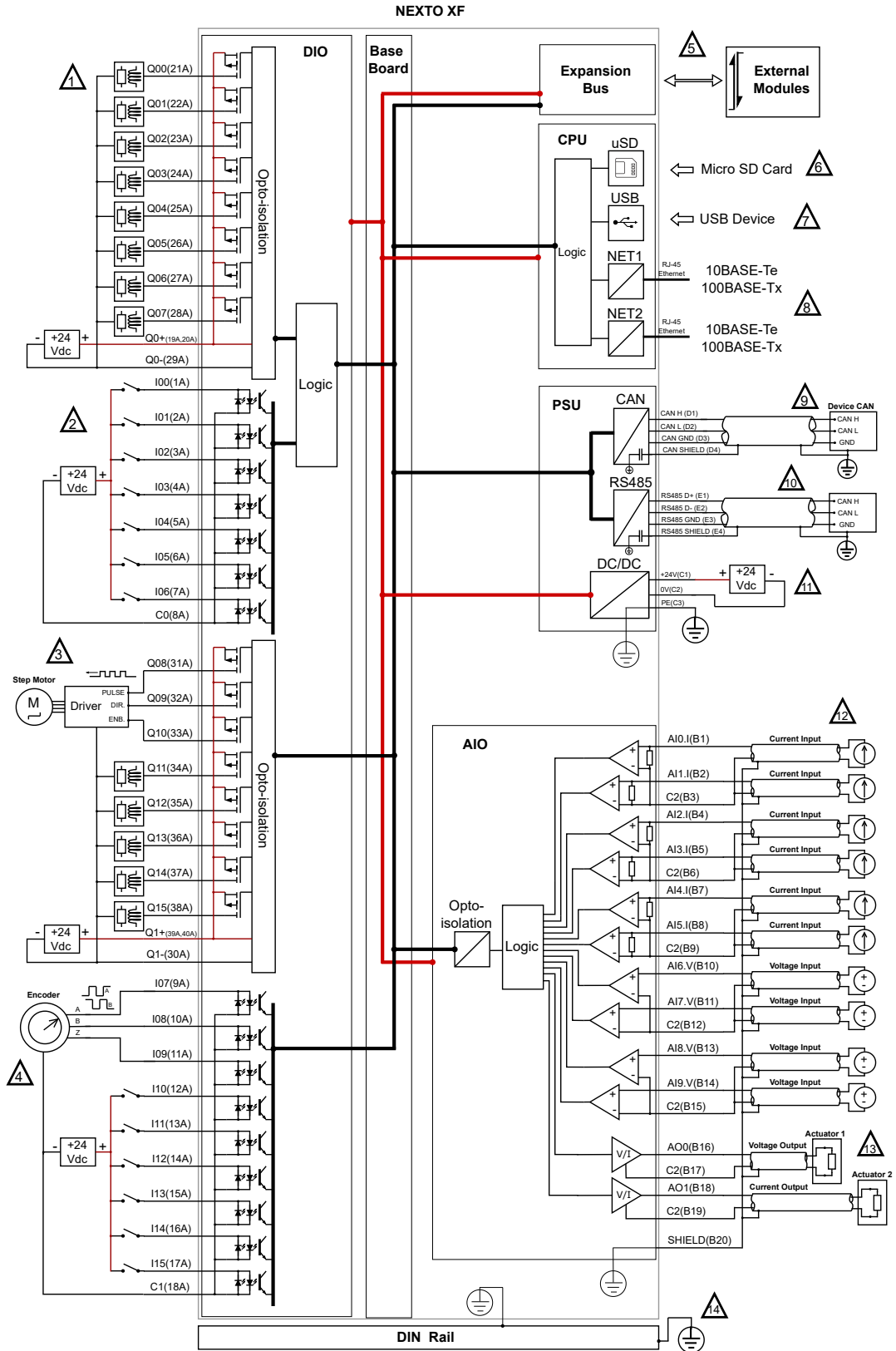

















Figure 2: XF3xx electrical wiring diagram

**Diagram notes:**

-  Typical connection of the isolated digital outputs Q00 to Q07 (source type). Independent external 24Vdc power supply connected to terminals Q0+ and Q0-.
-  Typical connection of the isolated digital inputs I00 to I06 (sink type). Independent external 24Vdc power supply connected to the common terminal C0 and switch contacts.
-  Typical connection of the isolated fast digital outputs Q08 to Q15 for stepper motor control and discrete load activation. Independent external 24Vdc power supply connected to terminals Q1+ and Q1-.
-  Typical connection of the isolated fast digital inputs I07 to I15, with a 3-signal encoder (A, B, and Z) and discrete switches. Independent external 24Vdc power supply connected to the common terminal C1 and switch contacts.
-  I/O Expansion Modules bus connection to external modules or termination cover
-  Micro SD card slot.
-  USB device slot. Refer to the technical specifications table for the USB port to obtain the list of supported devices.
-  Use Ethernet cables specified in the Related Products section.
-  Typical connection of the CAN serial interface.
-  Typical connection of the RS-485 serial interface.
-  Connection of the system's power supply, nominally 24Vdc. Main grounding point of the system.
-  Typical connection for analog voltage and current inputs. Grounding of the cable shield occurs at a single point on the connector (not applicable to the XF300 and XF300-B).
-  Typical connection for configurable voltage and current analog outputs. As with the inputs, the cable shield is grounded at a single point on the connector (not applicable to the XF300 and XF300-B).
-  The grounding is performed through direct contact of the product with a standard DIN rail, which must be metallic and connected through a proper external grounding.
-  Protective earth terminal.

The product has in its mechanics a label that identifies it and in it are presented some symbols whose meaning is described below:

 Attention! Before using the equipment and installing, read the documentation.

 Direct Current.

**ATTENTION**

Products with broken warranty seal are not covered in warranty.

**CAUTION**



The device is sensitive to static electricity (ESD). Always touch in a metallic grounded object before handling it.

### 5.3. Connector Pinouts

The following tables show the descriptions of each terminal on the connectors:

Terminal number	Description	Signal
1	24 Vdc power input	+24V
2	0 Vdc power input	0V
3	Protective earth	PE

Table 27: Power Input Connector

Terminal number	Description	Signal
1	CAN high differential signal	H
2	CAN low differential signal	L
3	Common of the CAN interface	GND
4	Cable shield connection	Shield

Table 28: CAN Interface Connector

Terminal number	Description	Signal
1	RS-485 data+ differential signal	D+
2	RS-485 Data- differential signal	D-
3	Common of the RS-485 interface	GND
4	Cable shield connection	Shield

Table 29: RS-485 Interface Connector

Terminal number	Description	Signal
1	Standard digital input 0	I00
2	Standard digital input 1	I01
3	Standard digital input 2	I02
4	Standard digital input 3	I03
5	Standard digital input 4	I04
6	Standard digital input 5	I05
7	Standard digital input 6	I06
8	Common for standard digital inputs	C0
9	Fast digital input 7	I07
10	Fast digital input 8	I08
11	Fast digital input 9	I09
12	Fast digital input 10	I10
13	Fast digital input 11	I11
14	Fast digital input 12	I12
15	Fast digital input 13	I13
16	Fast digital input 14	I14
17	Fast digital input 15	I15
18	Common for fast digital inputs	C1
19 e 20	Power supply for standard digital outputs	Q0+
21	Standard digital output 0	Q00
22	Standard digital output 1	Q01
23	Standard digital output 2	Q02
24	Standard digital output 3	Q03
25	Standard digital output 4	Q04
26	Standard digital output 5	Q05
27	Standard digital output 6	Q06
28	Standard digital output 7	Q07
29	Common for standard digital outputs	Q0-
30	Common for fast digital outputs	Q1-
31	Fast digital output 8	Q08
32	Fast digital output 9	Q09
33	Fast digital output 10	Q010
34	Fast digital output 11	Q011
35	Fast digital output 12	Q012
36	Fast digital output 13	Q013
37	Fast digital output 14	Q014
38	Fast digital output 15	Q015
39 e 40	Power supply for fast digital outputs	Q1+

Table 30: Digital I/O Connector

Terminal number	Description	Signal
1	Current analog input 0	AI0.I
2	Current analog input 1	AI1.I
3	Common of the analog interface	C2
4	Current analog input 2	AI2.I
5	Current analog input 3	AI3.I
6	Common of the analog interface	C2
7	Current analog input 4	AI4.I
8	Current analog input 5	AI5.I
9	Common of the analog interface	C2
10	Voltage analog input 6	AI6.V
11	Voltage analog input 7	AI7.V
12	Common of the analog interface	C2
13	Voltage analog input 8	AI8.V
14	Voltage analog input 9	AI9.V
15	Common of the analog interface	C2
16	Analog output 0	AO0
17	Common of the analog interface	C2
18	Analog output 1	AO1
19	Common of the analog interface	C2
20	Cable shield connection	Shield

Table 31: Analog I/O Connector

**Note:** Pin 1 of the connectors is located in the first position from left to right when viewed from the front of the connector.

### 5.4. Physical Dimensions

Dimensions in mm.

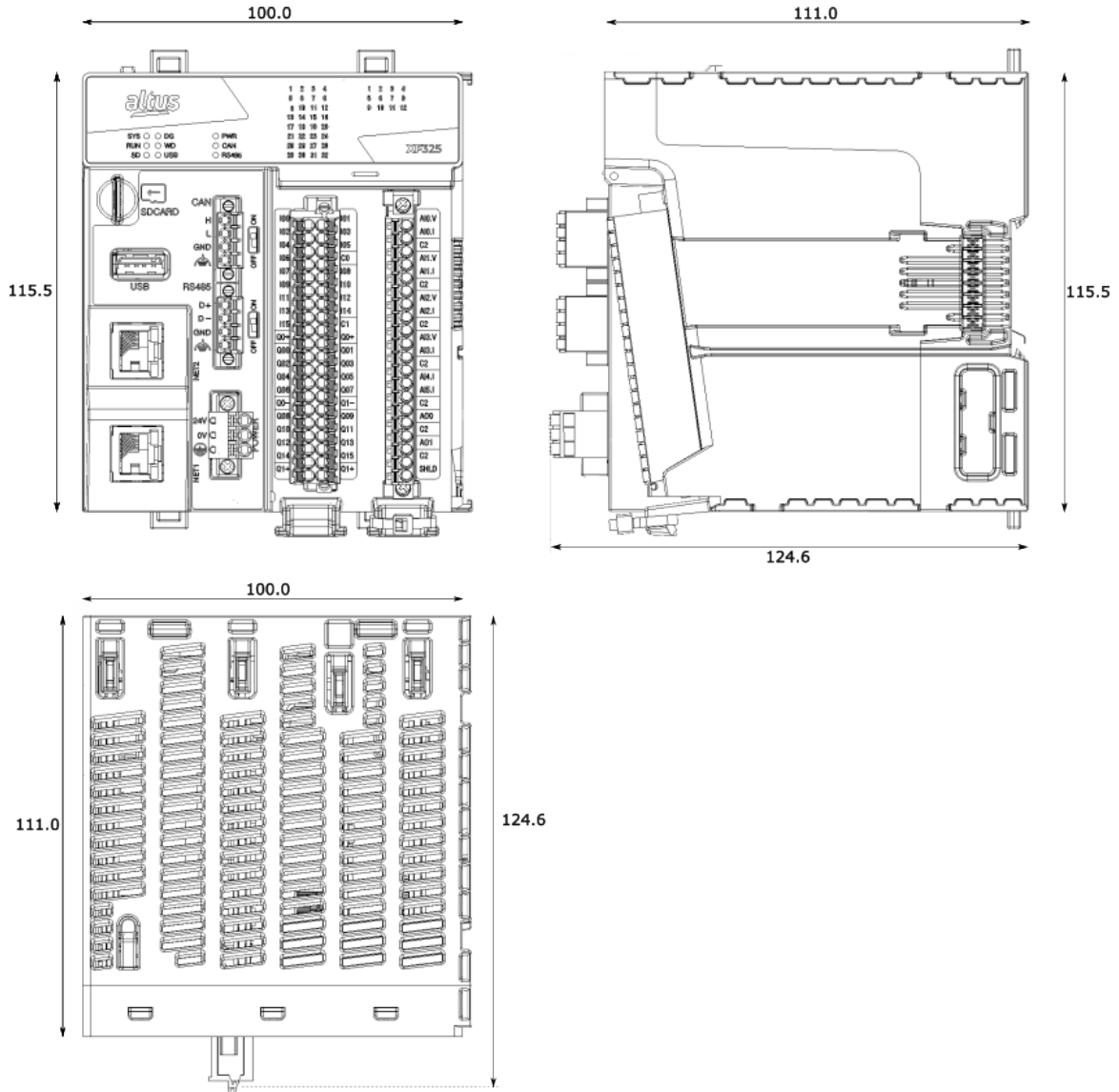

Figure 3: XF3xx Physical Dimensions

### 5.5. Protection Circuit

For further information, consult the "Lightning Protection" section of the Nexto Series User Manual - MU214600.

**ATTENTION**

Atmospheric discharges (thunders) may cause damages to the product although its protections. Additional protections should be used if the product's power comes from a power supply located outside the panel where it is installed because it could be vulnerable to this kind of discharges. If the field wiring of the output points is susceptible to this kind of discharge, surge suppressors should be used.

## 6. Manuals

For further technical details, configuration, installation and programming, the table below should be consulted.

The table below is only a guide of some relevant documents that can be useful during the use, maintenance, and programming of this product.

<b>Código</b>	<b>Descrição</b>	<b>Idioma</b>
<b>MU214600</b>	Nexto Series User Manual	English
<b>MU214606</b>	MQTT User Manual	English
<b>MU299610</b>	Mastertool X User Manual	English
<b>MU214609</b>	OPC UA Server for Altus Controllers User Manual	English
<b>MU214610</b>	PID - Advanced Control Functions User Manual	English
<b>MU214621</b>	Nexto Series PROFINET Manual	English
<b>NAP169</b>	RSTP in Nexto CPUs	English

Table 32: Related documents